

| REVISIONS | | | | |
|-----------|-----|-------------|------|----------|
| ZONE | REV | DESCRIPTION | DATE | APPROVED |
| | | | | |

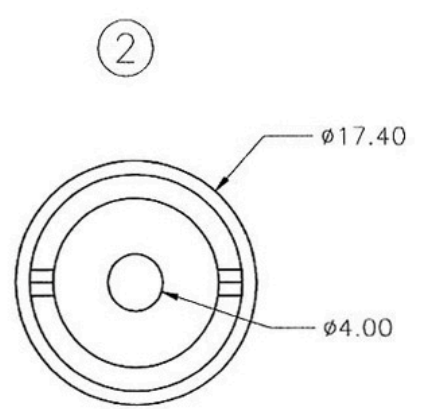
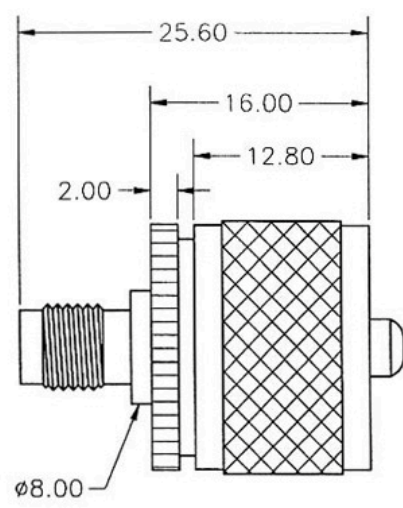
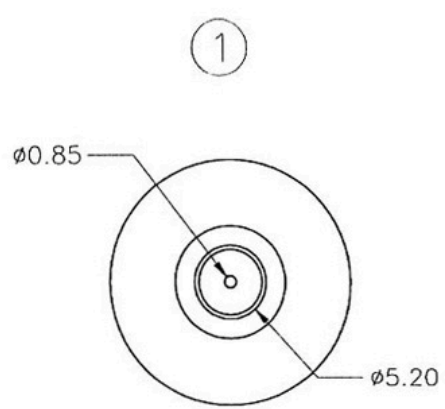

① SMA FEMALE
 ② UHF MALE
 NOTE: GOLD PLATED CENTER CONTACTS

Show Me
 C A B L E S

| | | | |
|-------------------|-----------|---------|--------|
| BY | DATE | PART NO | |
| DRAWN <i>R.M.</i> | 07/30/98 | | |
| CHK'D | | | |
| APPRV | | | |
| MATERIAL | SEE NOTES | | |
| FINISH | SEE NOTES | UNITS | SHEET |
| | | mm | 1 OF 1 |
| | | SCALE | NONE |