

NOTE: ALL MATERIAL COMPLIANT ROHS STANDARD

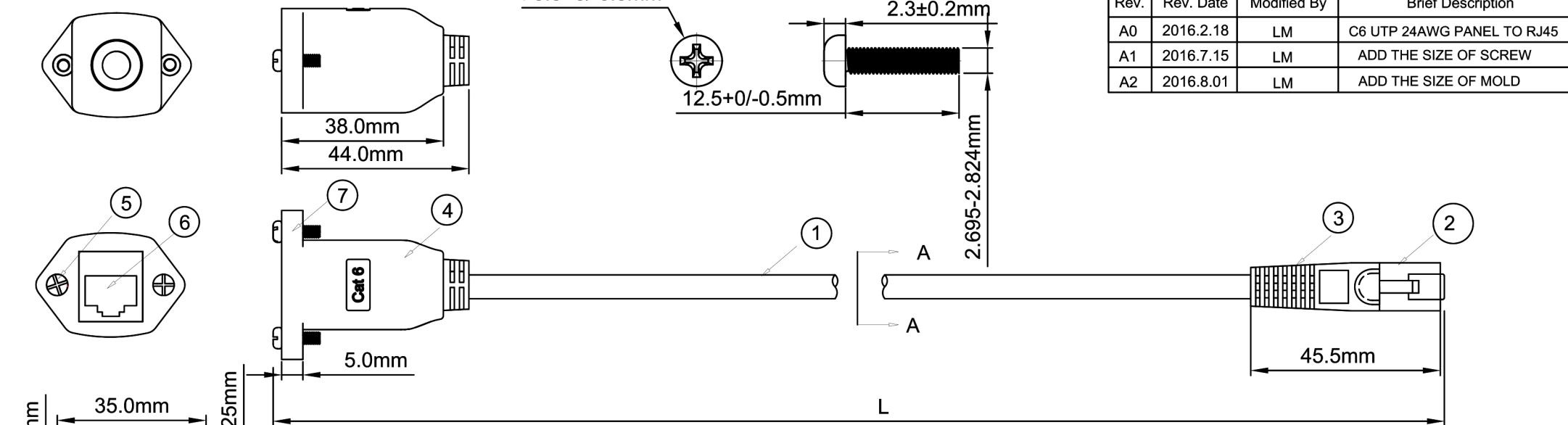

REVISION INFORMATION			
Rev.	Rev. Date	Modified By	Brief Description
A0	2016.2.18	LM	C6 UTP 24AWG PANEL TO RJ45
A1	2016.7.15	LM	ADD THE SIZE OF SCREW
A2	2016.8.01	LM	ADD THE SIZE OF MOLD

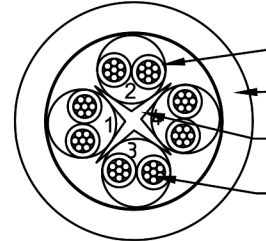
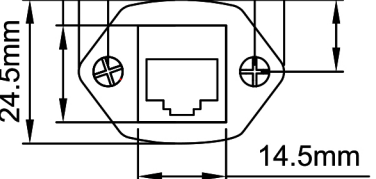

INSULATION:HDPE  
 JACKET:PVC OD=6.0±0.5mm  
 FILLER:PE  
 CONDUCTOR:[24AWG(7/0.196±0.008mm) BC]X4P

SUGGESTION:  
 THE PLUG IS BEST TO BE MOLDED.

PACKING&NOTE:  
 1.WITH CLEAR POLIBAG INDIVIDUALLY  
 2.BY 10 FOR 1FT,2FT,3FT LENGTHS  
 3.ASSEMBLY PASSES CAT6 CHANNEL TEST.  
 USING FLUKE OR SIMILAR TEST EQUIPMENT

SEC:A-A

orange 1	green 2
white/orange	white/green
blue 3	brown 4
white/blue	white/brown

Length(FT)	Tolerance(mm)
1	25
2	50
3	50
4	50
6	100
10	100
15	150
25	150

NO.	PART NAME	SPECIFICATION DESCRIPTION	QTY	UNIT
⑦	NUT	UNC #4-40 NUT,EMBEDDED,ELECTROPLATE	2	PCS
⑥	JACK	C6 JACK,WHITE HOUSING	1	PCS
⑤	SCREW	SCREW ,PAN-HEAD,UNC #4-40,5/16"(8mm) THREAD,0.3925"(12mm) LENGTH,ELECTROPLATE	2	PCS
④	MOLD	PLASTIC OVERMOLD WITH STRAIN RELIEF,BU608 (3015U) PVC,HARD:60-70P	1	PCS
③	MOLD	PVC YUS-07 BU608 (3015U)	1	PCS
②	PLUG	C6 RJ45 PLUG MALE TRANSPARENT	1	PCS
①	CABLE	C6 UTP 24AWG CM,PRINTING COLOR WHITE,CABLE COLOR BU608 (3015U) PVC	1	PCS



show Me  
CABLES  
cables & connectors since 1995

DRAWN BY	Title:	Panel-Mount Cat6 Ethernet Patch Cable- Standard Boot
CHECKED BY	SKU:	630-XX
APPROVED BY	SCALE 1:1	REV. 00 UNIT: mm